

2刃深沟圆鼻刀

2-flute Long Neck Corner Radius End Mill

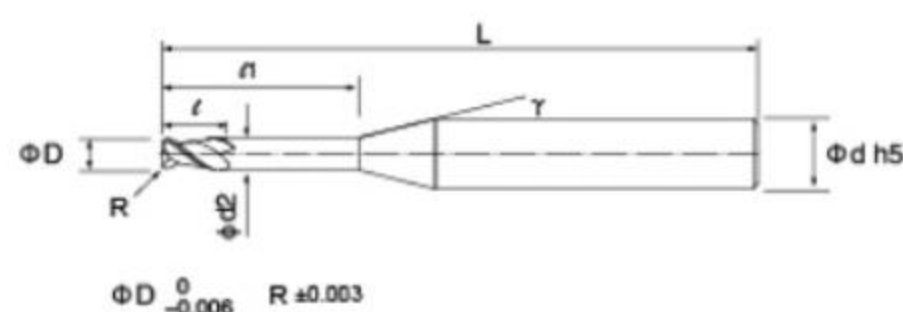
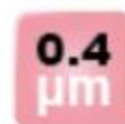

型号 No.	刃径 D	R角半径 R	颈长 L1	刃长 L	颈径 d2	颈角 γ(为参考值)	柄径 d	全长 L	定价 RMB
USR002-20020-010-04045	0.2	0.02	1	0.2	0.18	15°	4	45	45
USR002-20020-015-04045			1.5						
USR002-20020-020-04045			2						
USR002-20020-030-04045			3						
USR005-20020-010-04045		0.05	1	0.2	0.18	15°	4	45	
USR005-20020-015-04045			1.5						
USR005-20020-020-04045			2						
USR005-20020-030-04045			3						
USR002-20030-010-04045	0.3	0.02	1	0.3	0.27	15°	4	45	
USR002-20030-015-04045			1.5						
USR002-20030-020-04045			2						
USR002-20030-030-04045			3						
USR002-20030-040-04045		4							
USR005-20030-010-04045		0.05	1	0.3	0.27	15°	4		45
USR005-20030-015-04045			1.5						
USR005-20030-020-04045			2						
USR005-20030-030-04045	3								
USR005-20030-040-04045	4								
USR002-20040-010-04045	0.4	0.02	1	0.4	0.37	15°	4	45	
USR002-20040-015-04045			1.5						
USR002-20040-020-04045			2						
USR002-20040-030-04045			3						
USR002-20040-040-04045			4						
USR002-20040-050-04045			5						
USR002-20040-060-04045			6						
USR005-20040-010-04045			0.05						1
USR005-20040-015-04045		1.5							
USR005-20040-020-04045		2							
USR005-20040-030-04045		3							
USR005-20040-040-04045		4							
USR005-20040-050-04045		5							
USR005-20040-060-04045		6							
USR010-20040-010-04045		0.1		1	0.4	0.37	15°		4
USR010-20040-015-04045			1.5						
USR010-20040-020-04045	2								
USR010-20040-030-04045	3								
USR010-20040-040-04045	4								
USR010-20040-050-04045	5								
USR010-20040-060-04045	6								
USR002-20050-020-04045	0.5	0.02	2	0.5	0.46	12°	4	45	
USR002-20050-030-04045			3						
USR002-20050-040-04045			4						
USR002-20050-050-04045			5						

图示说明

Guide Lines to Icons

钨钢种类 Carbide



超微粒
Micro grain



极超微粒
Super micro grain

圆隅角 Corner R



圆隅角
Corner Radius

颗粒大小 Grain Size

0.2
μm

粉末颗粒是0.2μm
Grain size is 0.2μm

0.4
μm

粉末颗粒是0.4μm
Grain size is 0.4μm

刃数 Flute



镀层 Coating



氮铝化钛涂层
TiAlN



氮铬铝钛纳米涂层
AlCrTiN



超硬复合涂层
Superhard Composite Coating



DLC彩色涂层



钛硅复合涂层
SiTiNO Composite Coating